

Elixa Libra from Fabbri Group provides you with a range of Elixa packaging machines and integrated Weigh-Price-Labeling solutions to cater to your needs for space and performance. **Elixa Libra** is recommended for in-store packaging applications and small to medium sized packaging centres. Please ask our sales representative for more information on **Elixa Libra** (sales@gruppofabbri.com).

Dimensions

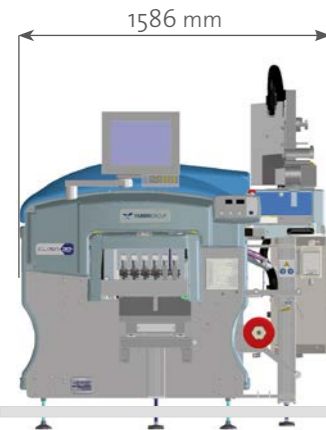

Elixa 30^L Libra Top Label

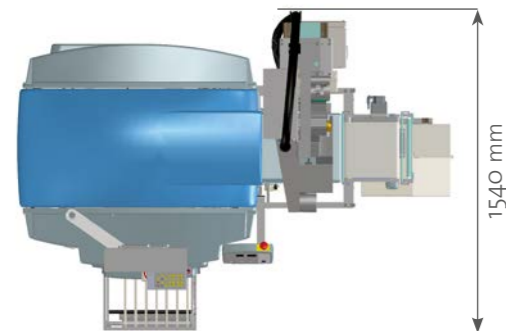
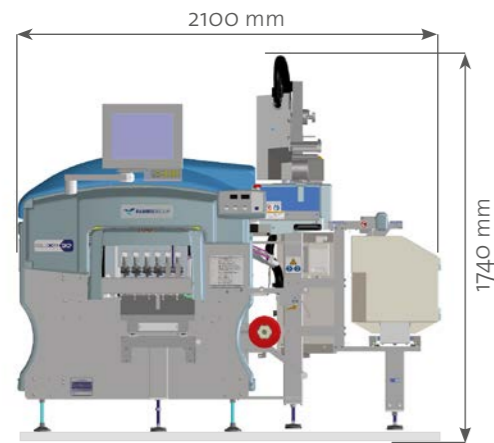

Elixa 30^L Libra Top & Bottom Label



Datasheet

General

- Performance Up to 30 ppm (wrap only)
- Direction Left to right
- Operating mode Wrap and label, Wrap only, Label only
- Label position Top & Bottom
- Display 15" TFT colour touch screen
- Interfaces USB, Ethernet TCP/IP, RS 232, Parallel
- Power source 230 V, 50/60 Hz

Wrapping

- Film type Stretch film
- Film width 330 mm (one single width for all types of product)
- Core diameter 111 mm, 76 mm
- Min. pack size 120 x 100 x 10 mm (L x W x H)
- Max. pack size 400 x 260 x 200 mm*
*(L x W x H - All 3 max. tray sizes cannot be achieved simultaneously)

Weighing

- Scale capacity Max. 6 kg
- Scale interval e = 2 g

Labelling

- Labeller 1 top labeller, 1 bottom labeller
- Label position Configurable also from monitor software
- Min. label size 37 x 30 mm
- Max. label size 104 x 170 mm (Top)
104 x 150 mm (Bottom)
- Label reel core 76 mm
- Max. label reel outside diameter 210 mm

Printing

- Max. print speed 250 mm/s (Top); 175 mm/s (Bottom)
- Max. print width 104 mm (4")
- Printer Direct thermal (TD) and thermal transfer (TTF) printers
- Resolution 12 dots/mm, 300 dpi
- Compressed air Not necessary

Main options

- Apparatus printed film
- Infeed extension
- Outlet conveyors
- Special trays modules

Fabbri Group provides quick and efficient technical assistance with a team of qualified and multilingual professionals across the globe. Please check our website for your nearest Service Centre (gruppofabbri.com).

DISCLAIMER: The content and information provided in this brochure are intended for general marketing purposes, therefore no subject (person or company) must consider them exact or complete. Gruppo Fabbri Vignola S.p.A., its company organisations, managers, officials, employees, agents and consultants will not be held liable (including liability resulting from error or negligence, without any limitation) for any direct or indirect loss, damage, cost or obligation which could have been suffered resulting from the use or reliance on that contained or omitted in this brochure. Gruppo Fabbri Vignola S.p.A. reserves the right to modify the specifics of its products without any prior notice. For further technical or economical information, please contact the Gruppo Fabbri Vignola S.p.A. Sales Department.

Weigh, Wrap, Label... All on Board!

ELIXA 30^L LIBRA
EN



Fabfri Group is presenting the **Elixa 30^L Libra** as the ready-to-use solution for Wrap-Price-Weigh and Label in the Retail and Food Industry. The Elixa wrapping technology is based on a single reel width for all tray sizes (family format and large-sized trays incl.) and has been designed to fit on a 1,5 m² footprint for in store packaging operations. This technology is now completed with on board Weigh-Price-Labeling solutions for Top and Bottom labels. In close collaboration with Espera, the **Elixa 30^L Libra** fulfills all today's requirements for label configuration and barcoding, weighing and data management integration into the customer's backoffice. Fabfri Group provides exclusive and comprehensive support for the complete installation, integration and service management of the **Elixa 30^L Libra**.

AUTOMATIC Intuitive Versatile
 Maximum **OPERATOR SAFETY**
 Best possible **PACK APPEARANCE**



USER FRIENDLY, CONFIGURABLE, MANY OPTIONS AVAILABLE

- Max operator safety
- Reliable and solid
- Automatic tray recognition
- Automatic weighing system
- Easy cleaning
- Customizable
- Technical service 360°

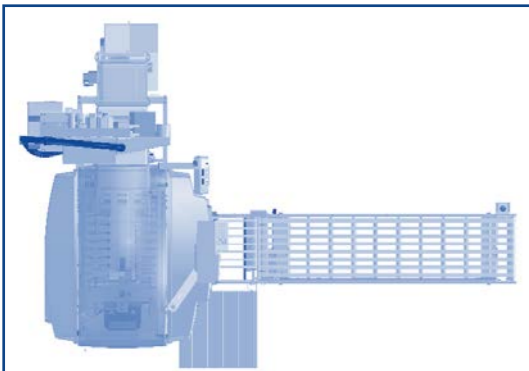

CUSTOMIZABLE WITH FG INSTORE SOFTWARE

- Handy key-pad
- 15" color touch-screen
- User-friendly software
- PC-based architecture
- Network connectivity
- Remote data management
- Remote service
- User on-line help
- Integrated label designer
- Integrated barcode designer



PERFECT FOR LARGE PRODUCTS

- 1 size roll (330 mm) for all trays
- Quick & simple film loading
- Optimised film consumption for extra savings
- Compatible with PVC-based, PE-based, biobased and compostable films



SUITABLE FOR THERMAL LABELS AND PREPRINTED LABELS

- Top & Bottom labelling options
- No compressed air needed
- Labelling application arm for optimised labelling on all surfaces
- Packaging & labelling speeds up to 32 ppm

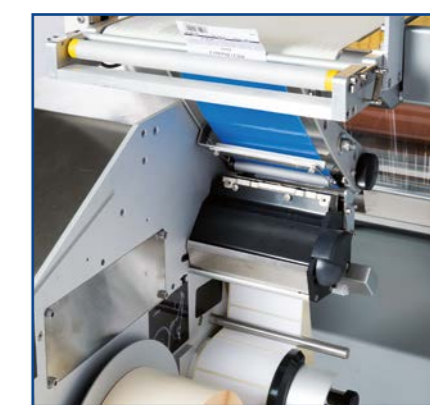

ELIXA 30^L LIBRA LABELLING OPTIONS

- Product detailed info and logo
- Product traceability
- Nutrition facts & allergens
- Product commercial info
- Barcodes
- Weight-depending price

Thank you for your purchase! **FABBRIGROUP**

CHICKEN BURGERS
 The finest, healthiest, tastiest pre-cooked meat!

INGREDIENTS: 80% Chicken, Pea Flour, Water, Sun Dried **TOMATOES** (4%), Basil, Garlic, Salt, Rice Flour, Leek Powder, Sugar, Spice, Preservative (Sodium **SULPHITE**), Yeast Extract, Natural Flavouring, Citric Acid, Spice Extracts Antioxidants (Ascorbic Acid, Herb Extracts)

ALLERGY ADVICE: See ingredients in **BOLD**

PACKAGING: Product packaged in a protective atmosphere
 EATING: To be consumed after thorough and accurate baking
 COOKING TIPS: Try 'em out with a fresh, crunchy lettuce, tomatoes and capers salad, thai rice with vegetables and a creamy mushroom sauce!
 >> See more on gruppo.fabfri.com/chickburgs >>

STORAGE INSTRUCTIONS: Keep cool (0° - 4°C); consume within 24 hrs after opening

Produced and packaged in Italy by GFV S.p.A., Via per Sassuolo 1863, Vignola (MO)

| | | |
|--------------------|---------------------|----------------------|
| Nutritional Info | Per 100 g (grilled) | Per Burger (grilled) |
| Energy | 448 kJ/106 kcal | 511 kJ/121 Kcal |
| Fat | 2.3 g | 2.6 g |
| of which saturates | 0.4 g | 0.5 g |
| Carbohydrate | 1.5 g | 1.7 g |
| of which sugars | 1.5 g | 1.7 g |
| Protein | 18.7 g | 21.3 g |
| Salt | 1.9 g | 2.2 g |

BORN IN: Italy
 BRED IN: Italy
 SLAUGHTERED IN: Italy
 CUT IN: Italy (Emilia-Romagna)
 LOT CODE: 132920

LOT OF PRODUCTION: 7288295296
 BEST BEFORE: 11.10.2016

TARE KG 0.014 NET WEIGHT 0.400 Kg e
 €/KG 6.325 **€ 2.53**

IT 9628 CE

9 437201 378224

FABBRIGROUP

THANK YOU FOR YOUR PURCHASE!

9 437201 378224

Patented 4-direction film stretching system for outstanding pack appearance with most common available trays

A product realised in co-operation with **ESPERA-WERKE GmbH**



All warranty, installation, service provided only by **Gruppo Fabfri** certified engineers.

