

## AUTOMAC 55 PIÙ

Automatic wrapper based on stretch technology, **Automac 55 Più** is the ideal choice for packaging centers that require high productivity.

**Automac 55 Più** is characterized by reliability, flexibility of use and its ergonomic design, a feature which is particularly appreciated by the operators.

**Automac 55 Più** is compliant with the most stringent existing safety standards and offers a comfortable and safe work area.

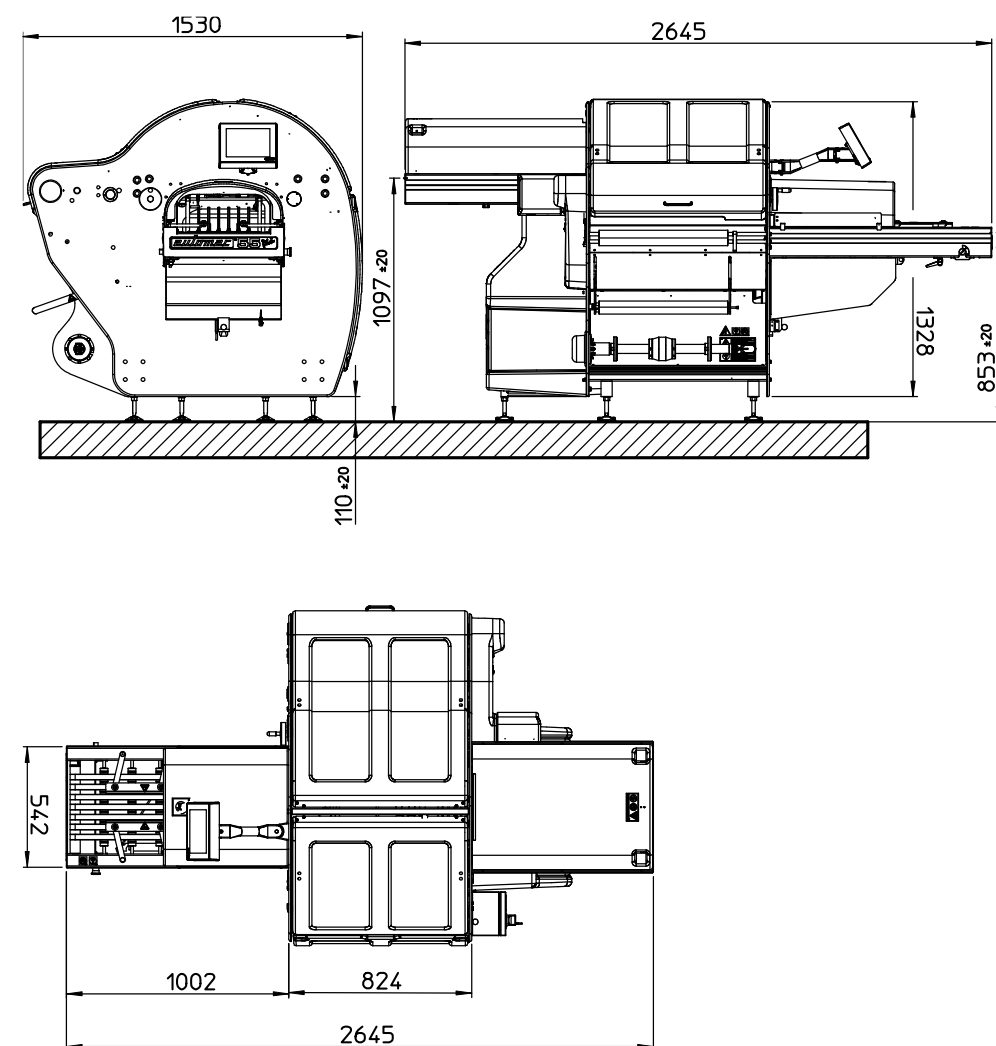

Ready. Resistant.  
Reliable. Industrial.

**AUTOMAC 55 PIÙ**  
EN





<b>Main characteristics</b>	
<b>Fast and flexible</b>	Automac 55 Più speed set-up (max. 55 ppm) allows to adapt the machine to a wide range of products.
<b>In line packaging machine</b>	Automac 55 Più can be fitted with extended in-feed conveyors and exit conveyor rollers that allow for best integration with your devices that are placed at the entrance and exit of the packaging machine. It is possible to equip Automac 55 Più with photocells and connections that allow for interaction with portioning machines and weigh-price labelling devices.
<b>Plug-and-Pack!</b>	Automac 55 Più is powered by 208, 230 or 400 V without any need for compressed air. The maximum in simplicity and silence!
<b>Seven independent access points: the comfort is priceless</b>	Automac 55 Più has 7 points of access to the internal parts of the machine, which allows for very easy access both for periodic cleaning operations and regular maintenance. The opening of the gull-wing safety guards is particularly useful in the lines where space is limited: once raised, the wings are positioned so as to facilitate film change operations as much as possible. There is nothing under the lift, if part of the product falls from the tray, it lands on the floor without intercepting any part of the machine. This guarantees the highest levels of hygiene and in case of cleaning, the operation is easy and definitely effective.
<b>Mission: to package trays of every shape, colour and size, always and well</b>	Automac 55 Più guarantees the packaging of every tray type, of the most varied and creative shapes and colours. Thanks to the many dedicated options, the optimal wrapping of trays ranging from catering types to large sized ones, is always guaranteed. The product is packaged with particular attention to the sealing of the tray underside: the sealing belt is designed to optimise the sealing of the film without overheating the tray. The automatically regulated upper ejector ensures high packaging speed even with high trays or with overflowing product, optimising production and eliminating any possibility of tray blockage in the machine.
<b>Reel replacement in less than 45 seconds!</b>	The film can be changed in about 45 seconds, guaranteeing immediate restart of production. The optional second reel support further reduces this time to a much lower 30 seconds. The reduced film reel weight makes the operation easier.
<b>Ideal for packaging fresh and very fresh products</b>	Meat, fish, fruit, vegetables, gastronomy, cheese, and more .
<b>Control panel with colour touch-screen monitor</b>	The monitor supplies all types of information with an interface featuring easy and intuitive use. Automac 55 Più can manage up to 29 wrapping programmes, guaranteeing customised programming that no other industrial machine can match. The integrated diagnostic system ensures complete control of the machine and allows for the quick identification of potential anomalies.
<b>Designed to package, built to amaze</b>	Automac 55 Più has been conceived to provide the best performance using plain and printed stretch film. Fabbri Group Graphic Dept. is at your disposal to create the best look for your product.
<b>The best ratio between performance and consumption</b>	If there are no trays in the in-feed or they arrive intermittently, Automac 55 Più automatically stops all movements, remaining on hold. This dramatically reduces the consumption of electricity and decreases mechanical wear to a minimum, allowing you to extend service intervals. Automac 55 Più runs fast but knows when to stop without any action on your part.
<b>Safety before anything else!</b>	Every part of Automac 55 Più has been designed in compliance with the most stringent regulations for operator safety: all machine parts are protected by safety switches for openable safety guards, by proper sizing of the covers on the in-feed and reinforced straps on the end sealing belt. There are no sharp edges on the metal parts and the rounded design of the aluminium sides minimises accidental impact during movement in the vicinity of the exit belt.

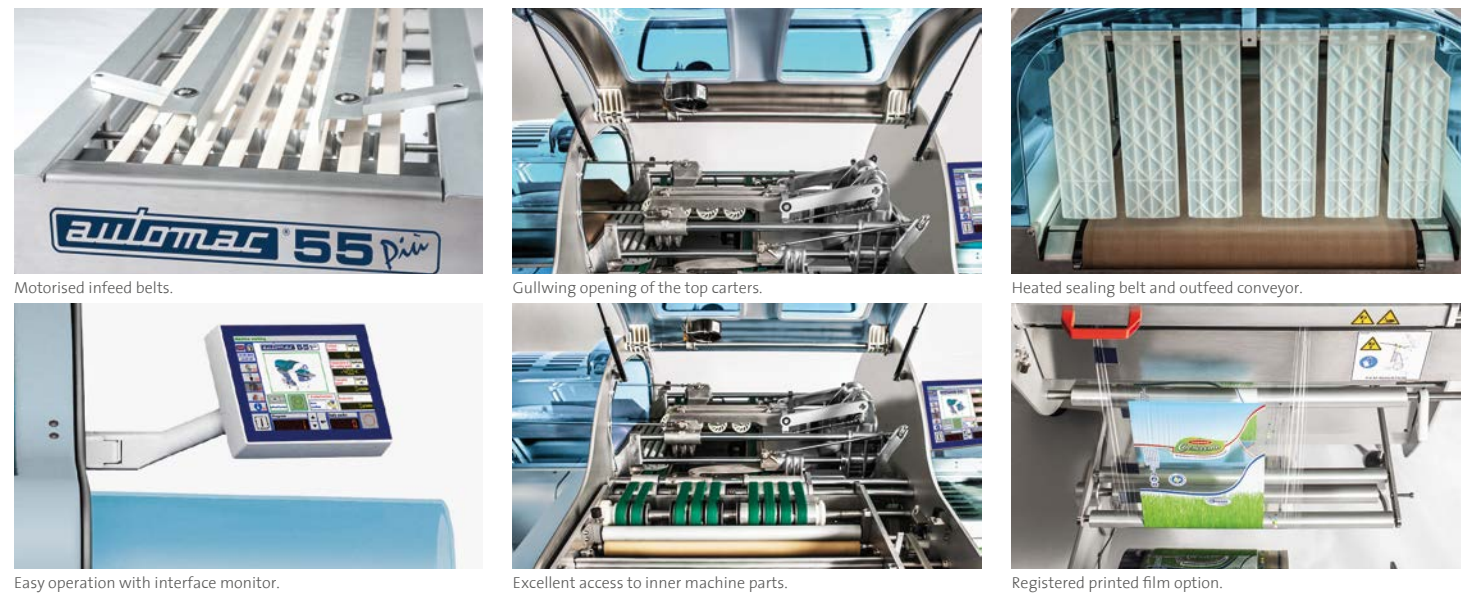

<b>45</b>	Seconds to change format.	<b>55</b>	Speed. From 25 to 55 packages a minute.	<b>29</b>	Wrapping programmes available.
<b>330</b>	Stretch film. Min reel width.	<b>550</b>	Stretch film. Max reel width.	<b>650</b>	Weight 630 kg.



<b>Optional devices</b>	<p>Extended in-feed conveyors up to 6 m.</p> <p>Anti-static in-line roller exit conveyor.</p> <p>Stainless steel top covers.</p> <p>Photocells for client belt and product exit control.</p> <p>Automatic carriage movement.</p> <p>Photocell for registered printed film.</p> <p>Support for second reel.</p> <p>Elevator for big trays.</p> <p>Side film-clamps device.</p> <p>Solutions for special trays.</p> <p>Motorized exit conveyors 90°/180°, right/left.</p> <p>Motorized tray-turning exit belt.</p> <p>Server TCP/IP connection.</p> <p>Teleservice and other optional features.</p>
-------------------------	---

<b>120</b>	Min tray format (L x W x H mm). With E lifter 120 x 120 x 10.	<b>180</b>	Min tray format (L x W x H mm). With A lifter 180 x 180 x 10.	<b>320</b>	Max tray format (L x W x H mm). With A lifter 230 x 320 x 200*.
<b>400</b>	Max tray format (L x W x H mm). With E lifter 250 x 400 x 200*.				

\* It is not possible to achieve the three maximum dimensions of the tray at the same time.

Gruppo Fabbri Vignola guarantees quick, efficient and widespread technical assistance, thanks to a team of qualified and multi-lingual professionals, always at the disposal of customers.

**DISCLAIMER:** The content and information provided in this brochure are intended for general marketing purposes, therefore no subject (person or company) must consider them exact or complete. Gruppo Fabbri Vignola, its company organisations, managers, officials, employees, agents and consultants will not be held liable (including liability resulting from error or negligence, without any limitation) for any direct or indirect loss, damage, cost or obligation which could have been suffered resulting from the use or reliance on that contained or omitted in this brochure. Gruppo Fabbri Vignola reserves the right to modify the specifics of its products without any prior notice. For further technical or economical information, please contact the Gruppo Fabbri Vignola Sales Department.